

MC45T Operating manual



Titel: MC45T Operating manual
Version: 0.1.0.9
Status:
Date: 2005-11-08
File: MC45T_UG_eng_051108.doc
Author: s.b.
Copyright: MC Technologies GmbH, Hannover/Germany

Table of contents, Page 2

1.1 Table of contents

MC45T OPERATING MANUAL	1
1.1 Table of contents	2
1.2 Table Index	2
1.3 Illustration Index	3
1.4 History/Status	3
2 PREFACE	3
3 SAFETY REFERENCES – STRONGLY RECOMMENDED TO READ!	4
4 TECHNICAL MANUAL	5
4.1 Equipment versions	5
4.2 Features	6
4.3 Front view	7
4.4 Rear View	7
5 INTERFACES	8
5.1 Voltage supply	8
5.1.1 Switch on the GSM/GPRS modems	10
5.1.2 Switch off the GSM/GPRS modem	10
5.1.3 Emergency shut-down of the GSM/GPRS modem	11
5.2 Hand set connection	11
5.3 SIM card holder	12
5.4 Antenna connection (FME)	13
5.5 RS-232 Interface	13
6 LED DISPLAY	14
7 AT COMMAND SENTENCE	14
8 SOFTWARE/FIRMWARE UPDATE	15
9 TECHNICAL DATA	15
9.1 Use of alternative voltage supplies	16
9.2 Protection from temperature rise	17
9.2.1 Information on use in longer GPRS - Class 10 connections	17
10 DIMENSIONS	18
11 PERMISSIONS, CONFORMITY	19
11.1 Cellular Engines, Type Approvals	19
11.2 GSM/GPRS modem	21
11.2.1 FCC Conformity	23
11.2.1.1 MC45T/MC45TL	23
11.2.1.2 MC46T/MC46TL	24
11.3 Adherence to international rules and regulations	25
11.3.1 SAR- guidelines for 'handheld mobiles'	25
12 ACCESSOIRES	25
13 CLEANING OF THE EQUIPMENT	25
14 MAINTENANCE, REPAIR	26
15 SHORT TERMS	26

1.2 Table Index

Table 1: History/Status	3
Table 2: Sources of information in the InterNet	4
Table 3: Equipment variant	6
Table 4: GPRS Class, Coding Scheme and data transmission rate	6
Table 5: Product overview	7
Table 6: Connections at the front	7
Table 76: GSM status indication (yellow LED)	14
Table 218: Permissions of the Cellular Engines	20

1.3 Illustration Index

Illustration 121: Conformity explanation22

1.4 History/Status

Version	Date	Changes	Status
1.0	2004-02-26	Document creation	Preliminary
0.1.0.9	2005-11-08	Including "FCC"	---

Table 1: History/Status

COPYRIGHT

All rights of these documents, including translation, reproduction, duplication etc., reserved. Processing, duplication or spreading of any kind only with written permission.

© Copyright by MC Technologies GmbH Hannover/GERMANY

Source reference: Pictures, illustrations and data partially with friendly permission of the SIEMENS AG, Munich.

REGISTERED TRADE MARK

Use -, trading- and productnames (registered trade marks) are used without special marking. It mostly concerns registered and protected names and/or indications, whose use is subject to the legal regulations.

LIABILITY

All listed data, representations etc. are meant for means of product description only and are not to be understood as assured characteristics in a sense of law. Any claims for damages – for whatever legal reason - are excluded, as far as neither intention nor rough negligence are to be assumed.

No guarantee can be taken over for that the indicated circuits or procedures are (also partial) free of patent rights by others.

ACTIVITIES WHICH INVOLVE HIGH RISK

The equipment is not error-tolerant and was not developed nor manufactured, in order to be used or to be resold as an on-line control equipment in dangerous environments, which require error free achievement, such as needed with the use in nuclear operating systems, flight control, communication systems, air traffic control, direct life support devices or weapon systems, with which the malfunctioning of the software could possibly directly lead to death, personal injury or heavy physical injuries ("High Risk Activities").

The manufacturer and his suppliers reject any express or indirect guarantee for the use with High Risk Activities.

EXTERNAL LINKS

The further-referring external links used in the context of this document and on our InterNet sides (web pages) lead to offers and contents of other manufacturers and are not those of the responsible persons of the manufacturer and author. These respective references are as such recognizable from the context or separately characterized. We do not have any influence on contents held ready there and do not agree to these just by indicating them. In particular we strongly dissociate ourselves from statements made there.

We have checked external contents for possible law breakings to a reasonable extent. Offences of author -, brand- or personality rights or offences against competitive right on the web pages of other offerers were not apparent and are thus as unknown to us as any fulfilment of criminal offence.

NOTES FOR DEALERS, IMPORTERS, RETAILERS

The GSM/GPRS modem may only be distributed by authorized dealers and importers !

The dealer is obliged to instruct the customer and/or user of the GSM/GPRS modem into the regulations concerning the use of the GSM/GPRS modem. This duty to supply information includes a non-liability by the manufacturer.

The same obligations apply in a general manner to companies, which distribute the GSM/GPRS modem within a bundle, an equipment integration or similar !

Changes and mistakes reserved.

2 Preface

Thank you that you have chosen the MC45T.

The MC45T enables you to a large variety of possibilities in modern portable radio technology.

Please read this manual - in particular the safety references (see chapter 3 safety reference – strongly requested to read !, Page 4) – attentively.

This manual is primarily written for installers, developers and programmers, who would like to install the GSM/GPRS modem in plants and/or integrate in applications.

- Appropriate **electrotechnical based ground knowledge is presupposed !**
- When assembling, the necessary safety precautions and regulations are to be considered!

The GSM/GPRS modem is a professional modem for transmitting speech and data in mobile radio nets! Extensive knowledge of modem -, GSM- and GPRS technology is absolutely necessary!

In the case of questions or disturbances contact the dealer, of whom you purchased the equipment. If he should not be able to help you immediately one time, he will pass your request on and you will receive an answer as fast as possible.

You will also find further references in the InterNet.

Link	
www.mc45t.com	Current information on the MC45T Please visit this InterNet side regularly and if necessary download the current operating instructions and updates.

Table 2: Sources of information in the InterNet

For the use of the GSM/GPRS modem you additionally need:

- a SIM-card (3 V) of a GSM-networkprovider (so-called provider),
- a GSM-antenna¹,
- a power pack²,
- For a software or a firmware update you need a PC with the operating system Windows® 98, Me or XP and a free serial interface (see chapter 8, to page 15).
- In order to download current information you should have access to an InterNet connection.

MC Technologies GmbH
Ahrensburger Straße 8
30659 Hannover
Germany

For questions and suggestions please send us an email at cellulare@mc-technologies.net

3 Safety references – strongly recommended to read!

Please consider the following safety references:

- **Switch the GSM/GPRS modem off in hospitals and/or when near medical instruments such as cardiac pacemakers or hearing aids. This could disturb the function of the devices.**
- **When in traffic only use the telephone with a free speech mechanism!**
- **Switch the GSM/GPRS modem off in airplanes and secure it against unintentional switching on.**
- **Switch the GSM/GPRS modem off when near highly combustible areas such as gas stations, fuel depots, chemical plants, blasting works. The GSM/GPRS modem could disturb technical mechanisms.**
- **Do not operate the equipment in the proximity of combustible gases, steams or types of dust.**
- **The SIM-card can be taken out. Caution! Infants could swallow these.**
- **The equipment may only be operated in clean, dry rooms.**
- **Do not expose the equipment to strong vibrations or impacts**
- **Do not cover the GSM/GPRS modem! The slots around the plug connectors may not be covered. When installing the GSM/GPRS modem make sure of good exhaustion of the assembling place!**

¹ Unless specially mentioned, in this manual the designation "MC45T" is used for all versions of equipment.

² The designation "Modem" stands for "**Mod**ulator/**Dem**odulator".

³ The gsm-antenna is partly contained in the range of supply.

⁴ The power pack is partly contained in the range of supply.

- **No objects or liquids may penetrate the GSM/GPRS modem! In case of water, coke, coffee e.g. getting into or over the GSM/GPRS modem, return to your dealer for check!**
- **If the equipment should warm up more than lukewarm, then switch it off immediately!**
- **The main voltage indicated on the plug power pack may not be exceeded.**
- **Only use power packs and accessories, which are certified for the enterprise with the GSM/GPRS modem!**
- **If you do not use outdoor aerials, do not let the antenna rise up outside of protected buildings (danger of lightning!)!**
Switch the equipment off in a thunderstorm and secure the antenna against lightning!
- **The antenna should be held away as far as possible from the body, in particular from the head.**
- **The call tone is also shown over the hearing cap. In order to avoid hearing damage, first accept the call, then hold the hearing mechanism to the ear.**
- **The GSM/GPRS modem can cause disturbances when in the proximity of television sets, radios or PCs.**
- **Using the GSM services (speech connections, SMS - and fax messages, data communication, GPRS etc..) is liable to cause costs!**
For these costs you as user will be made responsible!
In order to avoid unnecessary costs, when in use absolutely pay attention to the GSM connection and interrupt unnecessary or incorrect connections. The manufacturer, his suppliers and retailers reject any responsibility for the enterprise. The user himself is exclusively responsible for any damages and costs!
- **The GSM/GPRS modem may not be opened in any case. Any change of the equipment is inadmissible and leads to the loss of the operating permit.**
- **Inappropriate use, connection, operation and neglect of the operating instructions exclude any guarantee!**
- **Examine the cables and lines for damages. Damaged cables and lines have to be replaced immediately.**
- **Cable- and line connections, exchange of the SIM-card may only take place in a condition without voltage!**
- **Repairs may only be made by specialists who are authorized by the manufacturer!**
- **This document is considered as part of the equipment. If you pass the equipment on, then also pass on all documents.**

- **In addition to the mentioned safety references possibly further regulations must be considered with the enterprise of the equipment. These depend on the specific application and the laws of the countries, in which the equipment is purchased and operated. In any case please inquire about the regulations valid for your application!**

4 Technical manual

The MC45T is a GSM /GPRS modem for the transmission of voice, data, SMS- and fax message, WAP- and GPRS services in GSM nets

4.1 Equipment versions

The GSM/GPRS modem is offered in different versions. These differ in the GSM frequency band, -extent and GPRS classes:

Equipment variant		GPRS multislots class	EGSM 900	GSM 1800	GSM 1900	GSM 850	GSM-Rail	Cellulare Engine
MC45T	Triband	10	✓	✓	✓	-	-	SIEMENS MC45
TC45T	Dualband	8	✓	✓	-	-	-	SIEMENS TC45
MC388T	Dualband	8	✓	✓	-	-	-	SIEMENS MC388
MC46T	Triband	10	-	✓	✓	✓	-	SIEMENS MC46
TRM:1 Terminal	Triband	10	✓	✓	-	-	✓	Triorail TRM:1
✓ available		- not available						

Table 3: Equipment variant

Coding Scheme	1 Timeslot	2 Timeslot	4 Timeslot
CS-1:	9,05 kbps	18,1 kbps	36,2 kbps
CS-2:	13,4 kbps	26,8 kbps	53,6 kbps
CS-3:	15,6 kbps	31,2 kbps	62,4 kbps
CS-4:	21,4 kbps ¹⁾	42,8 kbps ³⁾	85,6 kbps ^{2) 4)}

¹⁾ max. Uplink with GPRS-multislot class 8
²⁾ max. Downlink with GPRS-multislot class 8
³⁾ max. Uplink with GPRS-multislot class 10
⁴⁾ max. Downlink with GPRS-multislot class 10

Table 4: GPRS Class, Coding Scheme and data transmission rate

Unless specially mentioned, in this manual the designation "MC45T" and/or "GSM/GPRS modem" is used for all versions of equipment.

4.2 Features

Product description:	<ul style="list-style-type: none"> ▶ MC45T: Tri-Band: EGSM900, GSM1800, GSM1900 ▶ MC46T: Tri-Band: GSM850, GSM1800, GSM1900 ▶ TRM:1 Terminal: Tri-Band: GSM-R, EGSM900, GSM1800 ▶ TC45T: Dual-Band: EGSM900, GSM1800 ▶ MC388T: Dual-Band: EGSM900, GSM1800 ▶ GSM phase 2/2+ ▶ Output power: <ul style="list-style-type: none"> • Class 4 (2 W) for GSM850 and EGSM900 • Class 1 (1 W) for GSM1800 and GSM 1900 ▶ Control via AT commands ▶ Supply voltage reange: 8 - 30 V ▶ Compact housing; Dimensions: 65 x 74 x 33 mm ▶ Weight: approx. 130 g ▶ SIM application tool kit (SAT): class 3, GSM 11.14 Release 98
Certifying:	<ul style="list-style-type: none"> ▶ ▶
Audio:	<ul style="list-style-type: none"> ▶ Half rate (HR) ▶ Full rate (FR) ▶ Enhanced full rate (EFR)
SMS:	<ul style="list-style-type: none"> ▶ Point-to-point MT (Mobile Terminated) and MO (Mobile Originated) ▶ SMS Cell Broadcast ▶ Text Mode ▶ PDU Mode ▶ SMS-(Memory-)Register in the SIM card and 25 in the Engine ▶ Transmission over CSD (Circuit Switched Data) or GPRS
Daten, CSD (Circuit Switched Data):	<ul style="list-style-type: none"> ▶ CSD-Data transmission rates: 2,4; 4,8; 9,6; 14,4 kbps ▶ USSD support (Unstructured Supplementary Services Data) ▶ Non-transparent mode ▶ V.110
GPRS:	<ul style="list-style-type: none"> ▶ MC45T: GPRS multi slot class 10 ▶ MC46T: GPRS multi slot class 10 ▶ TRM:1 Terminal: GPRS multi slot class 10 ▶ TC45T: GPRS multi slot class 8 ▶ MC388T: GPRS multi slot class 8 ▶ Coding scheme CS 1, 2, 3, 4 ▶ GPRS mobile station class B ▶ GPRS data transmission (downlink): max. 85,6 kbps ▶ MC45T: GPRS data transmission (uplink): max. 42,8 kbps ▶ MC46T: GPRS data transmission (uplink): max. 42,8 kbps ▶ TRM:1 Terminal: GPRS data transmission (uplink): max. 42,8 kbps ▶ TC45T: GPRS data transmission (uplink): max. 21,4 kbps

	<p>MC388T: GPRS data transmission (uplink): max. 21,4 kbps</p> <ul style="list-style-type: none"> ▶ PAP support (Password Authentication Protocol) ▶ CHAP support (Challenge Handshake Authentication Protocol) ▶ PBCCH support (Packet Switched Broadcast Control Channel) ▶ PPP-stack ▶ WAP compliant
Fax:	▶ Group 3: Class1, Class 2
Supplementary services:	<ul style="list-style-type: none"> ▶ Phone book ▶ Multiparty ▶ DTMF (Dual Tone Multi Frequency)
Interfaces:	<ul style="list-style-type: none"> ▶ Western modular socket for hand set ▶ (3 volt) miniature SIM-card holder ▶ Antenna socket FME, 50 Ω (male)
	▶ Standardized RS232 interface (V.24, 9-pin sub-D socket)
	▶ LED-display for net and operating status
<p>The GSM/GPRS modem may be installed and served only by accordingly technically qualified persons.</p> <p>The GSM/GPRS modem may be operated only with power packs according to EN60950. The feeder may not exceed 2 m.</p> <p>A fuse should be inserted by 1,0 A (speedy) into the plus wire of voltage supply for reasons of protection the GSM/GPRS modem.</p>	

Table 5: Product overview

4.3 Front view

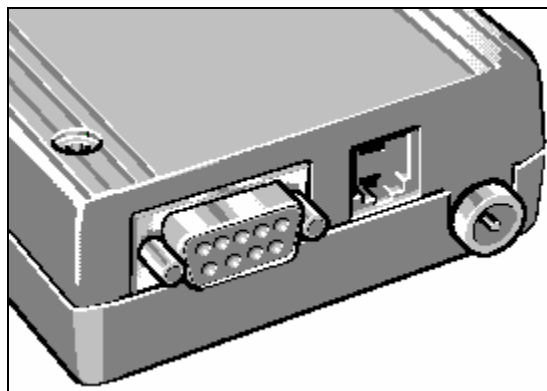

Illustration 1: front view

Connection	Description	Chapter
RS232 Interface (9-pin D-Sub)	Connection to the personal computer/notebook	RS-232interface Page 13
Voltage supply (western with 6 pins modular plugs)	Connection of the plug power pack	Power supply Page 9
Antenna connection (FME)	Connection of the antenna	Antenna connection (FME) Page 13

Table 6: Connections at the front

4.4 Rear View

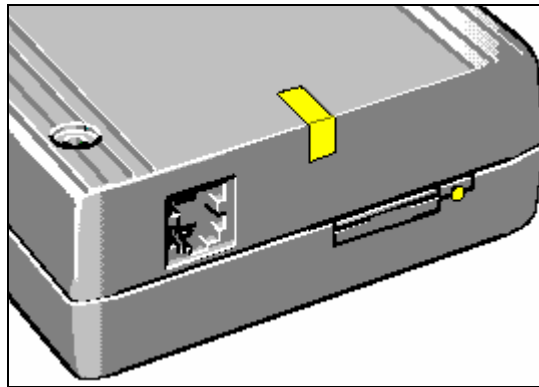

Illustration 2: rear view

Connection	Description	Chapter
Hand set connection (4-pin western modular plug)	Connection of the hand set	Hand set connection Page 11
LED-display (2 colour LED-display)	Mode and status indication of the GSM connection	LED display Page 14
Miniature SIM-card holder	Holder (table slot) for adapting a SIM-card	SIM card holder Seite 12

Table 7: Connections and mechanisms at the back

5 Interfaces

5.1 Voltage supply

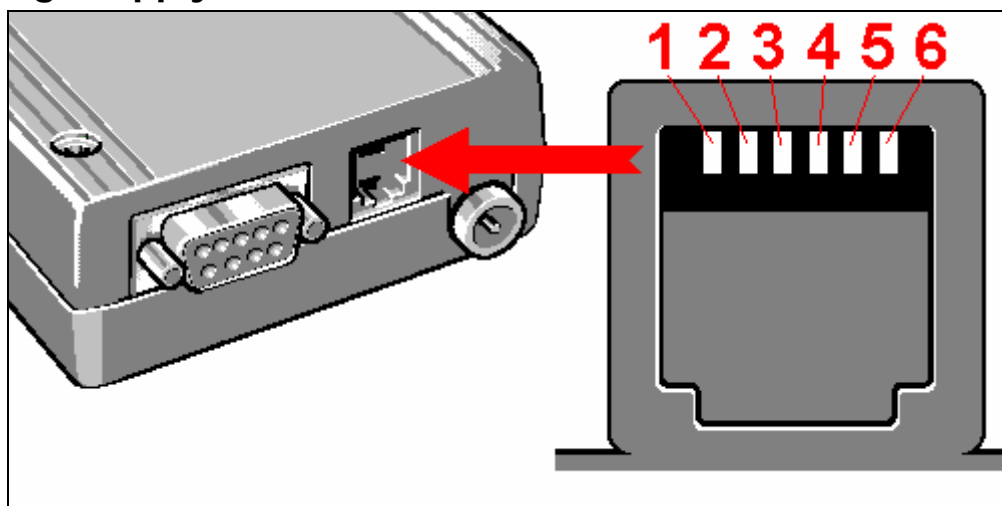

Illustration 3: Voltage supply ,clinch connector (6-pin western modular plug)

Pin	Designation	I/O ³	Description	Parameter
1	PLUS	I	positive supply voltage	+8V to +30V
2	(reserved, internally connected, is not to be connected!)			
3	PD_IN	I	Input 'NOTAUS	$U_{PD_IN, in, high} > 2\text{ V}$
4	IGN_IN	I	Input 'IGNITION'	$U_{IGN_IN, in, high} > 2\text{ V}; T_{high} > 200\text{ ms}$

³ Input: 'I'; Output: 'O'

Pin	Designation	I/O ³	Description	Parameter
5	(reserved, internally connected, is not to be connected!)			
6	MINUS	I	negative supply voltage	0 V

Table 8: Power supply, connection allocation

- Voltage supply must be attached at pin 1 (PLUS) and pin 6 (MINUS).
- Only use power packs according to EN60950!
- The feeder should not exceed a length of 2 m.
- Secure the plus-line by a 1 ampere fuse (speedy).
- Should you not use the provided power pack, then absolutely consider that depending upon the regulations of the country, in which the modem is operated it may be necessary to put an EMI filter in the feeder.

5.1.1 Switch on the GSM/GPRS modems

The GSM/GPRS modem can be switched on only by one of the following three methods:

Switching on procedure	Connection	Parameter
Positive voltage flank at IGN_IN	Voltage supply, pin 4	$U_{IGN_IN, in, low} < 0,5 V$
		$U_{IGN_IN, in, high} > 2 V$
		$U_{IGN_IN, max} < 30 V$
		$T_{IGN_IN, in, high} > 200 ms$
		$R_{IGN_IN} > 100k\Omega$
Positive voltage flank at DTR	Serial interface, pin 4	$U_{DTR, in, low} < 0,6V$
		$U_{DTR, in, high} > 3,2 V$
		$T_{DTR, in, high} > 200 ms$

- The GSM/GPRS modem is switched on by a positive flank at IGN_IN or DTR.
- In order to switch back on a positive flank must be made at IGN_IN and/or DTR again.
 - IGN_IN (power supply, Pin 4):
 1. Voltage on IGN_IN for at least 200 ms on a voltage of under 0,5 V ($U_{IGN_IN, in, low} < 0,5 V$).
 2. Voltage on IGN_IN for at least 200 ms on a voltage of 2 V to ($U_{IGN_IN, in, high} > 2 V$; ($U_{IGN_IN, in, high} > 2 V$; $U_{IGN_IN, max} < 30 V$).
 - or
 - DTR (serial interface, Pin 4):
 1. Voltage on DTR for at least 200 ms on a voltage of 0,6 V ($U_{DTR, in, low} < 0,6V$).
 2. Voltage on DTR for at least 200 ms on a voltage of over 3,2 V ($U_{DTR, in, high} > 3,2 V$).

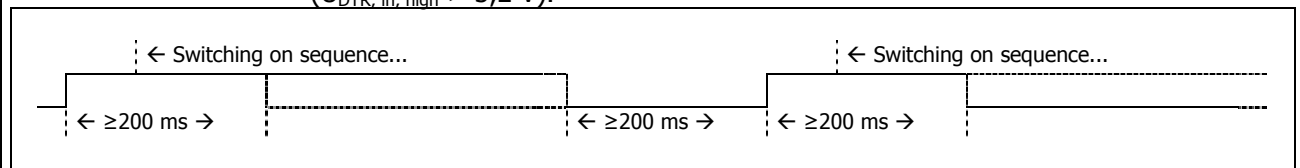

Table 9: Switch on the GSM/GPRS modem over IGN_IN and/or. DTR

- When IGN_IN is connected to PLUS, then the GSM/GPRS modem is switched on immediately after supply voltage has been set up.
- After switching on, wait a few seconds until the initialisation of the GSM/GPRS modem is completed and only send the first AT commands after that.

Table 10: Switch on the GSM/GPRS modem

5.1.2 Switch off the GSM/GPRS modem

When (normal) switching off of a GSM-equipment the following happens:

- a notice of departure to the GSM network
- and
- storage of important parameters on the SIM-card and in the equipment, which are necessary for a faster reregistration at the GSM network.

After input of the AT-instruction "AT^SMSO" the GSM/GPRS modem carries these tasks out automatically.

Never switch off the supply voltage of the GSM/GPRS modem abruptly! This could cause irreversible damage to the SIM-card or to the GSM/GPRS modem!

Always proceed as follows:

1. Send the AT-command "AT^SMSO" to the GSM/GPRS modem
2. The GSM/GPRS modem must acknowledge the command with the report "OK".
3. Still wait for a few seconds, until the GSM/GPRS modem has duly logged itself out of the GSM network and has terminated access to the SIM-card.
4. When all LEDs on the GSM/GPRS modem have gone out, you can switch off the voltage supply.

5.1.3 Emergency shut-down of the GSM/GPRS modem

If an emergency shut-down of the GSM/GPRS modem should become necessary, then apply a voltage of at least 2 V to the connection PD_IN (Power supply, Pin 3).

Emergency shut-down	Connection	Parameter
Positive voltage at PD_IN	Voltage supply , pin 3	$U_{PD_IN, in, low} < 0,5 V$
		$U_{PD_IN, in, high} > 2 V$
		$U_{PD_IN, max} < 30 V$
		$T_{PD_IN, in, high} > 200 ms$
		$R_{PD_IN} > 100k\Omega$

Table 11: Emergency shut-down of the GSM/GPRS modem

5.2 Hand set connection

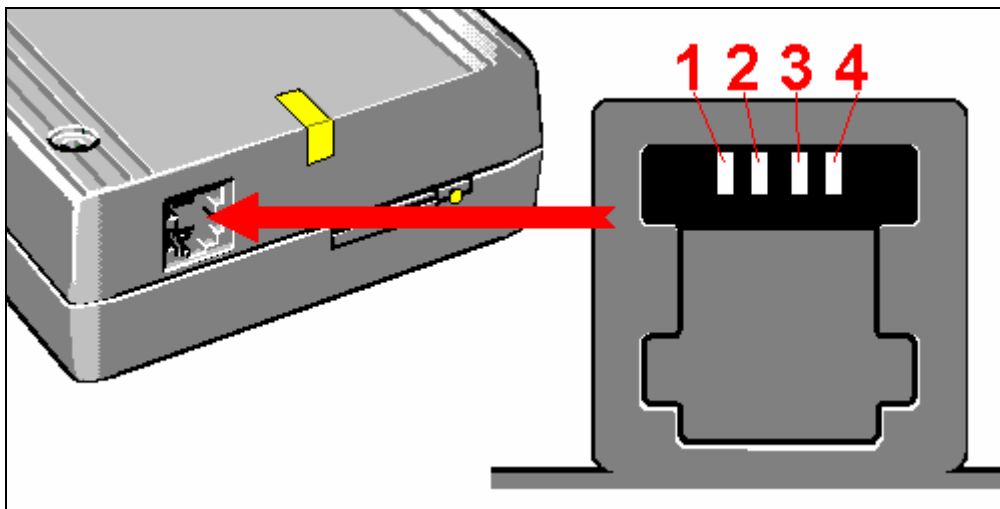

Illustration 4: Hand set connection (4-pin miniature western plug)

Pin	Designation	I/O	Description	Parameter
1	MICN	I	Microphone-input, minus	DC (no load): $U_0 = 2,9 V \pm 10\%$ (MICP) $U_0 = 0 V$ (MICN) $R_i = 1.5 k$ (MICP) $R_i = 1.5 k$ (MICN) AC: $U_{imax} = 1.03 V_{PP}$
2	EPN	O	Headphone-output, minus	$U_{0max} = 3,7 V_{PP}$, no load
3	EPP	O	Headphone-output, plus	$R_i = 15 \Omega$
4	MICP	I	Microphone-input, plus	(look MICN)

Table 12: Hand set connection, connection allocation

The GSM/GPRS modem is appropriate for the hand set "HH-SI-30.3/V1.1/0" by VOTRONIC GmbH in the audio mode 4.

For this give the following AT-instructions into the audio Setup:

`AT^SNFS=4`

`AT^SNFI=5,20000`

Audio Mode	Notice
Mode 1:	Audio configuration for the enterprise of the hand set.
Mode 4:	Audio configuration for the enterprise of the hand set. Audio mode 4 (AT^SNFS=4) with the selection (AT^SNFI=5,20000) is to be preferred to audio mode 1.
Mode 5:	Frequency Responses: linear Echo Suppression: off Side Tones: switched off

Table 13: Audio Modes (selection)

5.3 SIM card holder

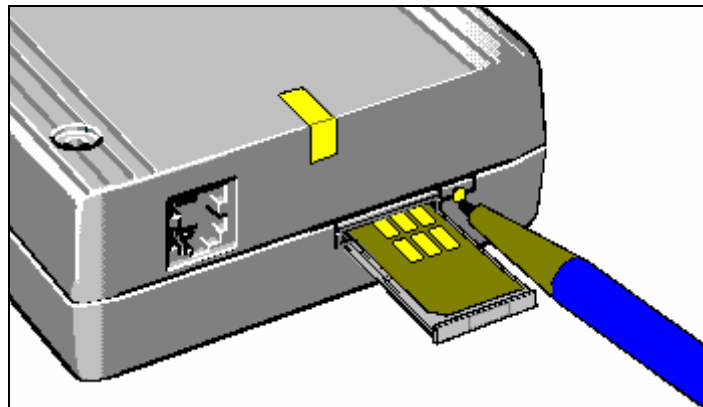

Illustration 5: SIM card holder

- For the enterprise you need a miniature-SIM-card (3 V, according to the guideline GSM 11.12).
- The SIM-card must be inserted into the holder ("table slot") on the back:
 1. Make sure that the modem is switched off (voltage supply disconnected!)
 2. Herefor press – for example with a pen – on the small yellow button next to the table of the holder. The table slot will then be moved out a little bit.
 3. Pull out the table slot and insert the SIM card.
Pay attention to the correct position: In the table slot there is a small cut off corner, so that the SIM-card can only be used in a defined position.
 4. Carefully push the table slot back into the MC45T. The table slot must glide back in easy and must not be wedged or jammed.

**The SIM-card may only be inserted or changed when the GSM/GPRS modem is switched off. Changing while still on voltage supply can lead to irreversible damage of the SIM-card and of the GSM/GPRS modem.
No objects or particles may be inserted into the slot of the drawer! If you remove the SIM-card, reinsert the empty table slot, so that no particles can penetrate!**

5.4 Antenna connection (FME)

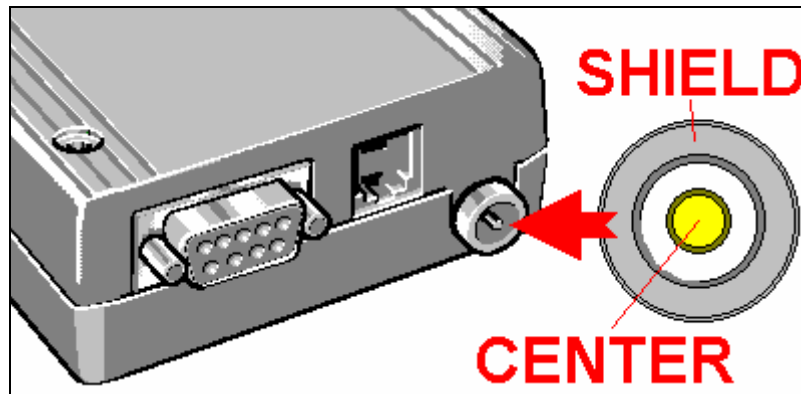

Illustration 6: Antenna connection (FME)

Pin	Designation	I/O	Description	Parameter
CENTER	RF	I/O	RF Input/Output	$Z_{RF} = 50 \Omega$
SHIELD	RF_GND	---	Shield	

Table 14: Antenna connection, connection allocation

Note that the antenna connection is a FME plug (50 Ω , male). Attach here only dual or tri-band antennas with FME connectors (50 Ω , female).

5.5 RS-232 Interface

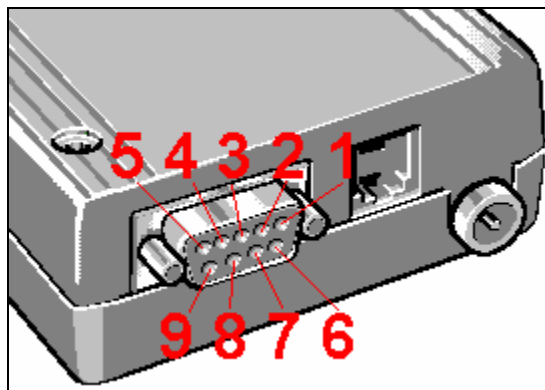

Illustration 7: RS-232 Interface

Pin	Designation	I/O	Description
1	DCD	O	Data Carrier Detect
2	RXD	O	Receive Data
3	TXD	I	Transmit Data
4	DTR	I	Data Terminal Ready
5	GND		Common
6	DSR	O	Data Set Ready
7	RTS	I	Request to Send
8	CTS	O	Clear to Send
9	RI	O	Ring Indicator

The designations correspond to the RS-232C standard of the EIA and/or the V.25 standard of the CCITT. The MC45T, as a modem, is considered as DCE (Data Carrier Equipment), a personal computer as DTE (Data Terminal Equipment). The designations accord themselves to a DTE, therefore "Receive Data" here means an exit.

Table 15: RS-232 Interface. connection allocation

The RS-232 interface is the interface between the GSM/GPRS modem and the application and/or the PC.

- Always use as short a cables as possible (max. 1.8 m).
- The input voltage may not exceed max. ± 15 V.
- Avoid short-circuits!
- Secure the patch cord with the screw connections at the plug.

6 LED display

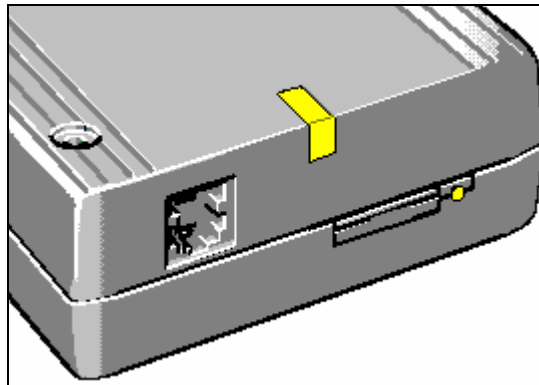

Illustration 8: LED display

As a check of the GSM- and operating status a two-coloured LED display is situated at the back and/or top side of the GSM/GPRS modem.

GSM status indication (yellow LED)	
off	GSM/GPRS modem in SLEEP- or ALARM-mode
600 ms on	SIM-card not inserted
600 ms off	PIN not entered
	Network search not yet finished
75 ms on 3 s off	Logged into the GSM net, no speech or data connection
75 ms on 75 ms off 75 ms on 3 s off	One or more GPRS connections are active
Blinking, flashing	GPRS dataTransfer GPRS dataTransfer is indicated within 1 second by (fast) flashing for 0.5 seconds.
on	with voice connections: Voice connection active
	with data connections: Set up of a data link, active data link or dismantling of a data link.

Table 76: GSM status indication (yellow LED)

Mode display (red LED)	
Blinking, approx. 5 times per second	GSM/GPRS modem will be switched on.

Table 17: Mode display (red LED)

In the case of an emergency shut-down (see chapter 5.1.3 emergency shut-down of the GSM/GPRS modem, page 11) both LEDs blink at the same time and very fast.

7 AT command sentence

The GSM/GPRS modem supports the AT-command sentence of the integrated Cellulare Engines (SIEMENS AG: MC45, TC45, MC46, MC388 oder Triorail: TRM:1). Ask your dealer for the current AT command sentence of your GSM/GPRS modem or visit the InterNet side www.MC45T.com.

8 Software/firmware update

For a better overview one differentiates here between software and firmware.

Software:	Program of the integrated Cellulare Engines: <ul style="list-style-type: none"> SIEMENS AG: MC45, TC45, MC46, MC388 or <ul style="list-style-type: none"> Triorail: TRM:1
Firmware:	Program of the integrated microcontroller. The microcontroller serves the control of function and voltage of the GSM/GPRS modem.

Table 18: Software/Firmware

The software of the Cellulare Engines and/or the firmware of the GSM /GPRS modem can be updated over the serial RS-232 interface.

Please examine regularly whether new software and firmware versions are available. Ask your dealer or visit the InterNet side www.MC45T.com.

- Examine before software and/or Firmware update the type of the integrated cellulare engines and the equipment version.
- With a software update only may be used updates, which have been proven to be appropriate for the Cellulare Engine (MC45, TC45, MC46, MC388 or TRM:1)!
A wrong software update can lead to the irreversible damage of the cellulare engine!
The type of the GSM/GPRS modem integrated cellulare engines can be found out with the command "ATI"!
- With a firmware update only may be used updates, which have been proven to be appropriate fo the according version of equipment!

9 Technical data

PARAMETER	MIN.	TYP.	MAX.	UNIT	CONDITIONS
Power supply ¹⁾					
Input voltage; V_{PWR}	8	12	30	V_{DC} (V_{DC})	
max. power input; $\hat{I}_{PWR,MAX,PEAK}$ ^{1) 2)}			4	A	$V_{PWR} = 12\text{ V}, 20^\circ\text{C}$
average power input (logged-in, no connection); $I_{PWR,IDLE}$		40	80	mA	$V_{PWR} = 12\text{ V}, 20^\circ\text{C}$
average power input (logged-in, voice call); $I_{PWR,TALK}$ ²⁾		85	130	mA	$V_{PWR} = 12\text{ V}, 20^\circ\text{C}$
average power input (logged-in, GPRS, 4*RX, 1*TX); $I_{PWR,GPRS,4RX1TX}$ ²⁾		100	120	mA	$V_{PWR} = 12\text{ V}, 20^\circ\text{C}$
average power input (logged-in, GPRS, 3*RX, 2*TX); $I_{PWR,GPRS,4RX1TX}$ ²⁾		150	220	mA	$V_{PWR} = 12\text{ V}, 20^\circ\text{C}$
Standby electricity; $I_{PWR,STBY}$		2	10	mA	$V_{PWR} = 12\text{ V}, 20^\circ\text{C}$
RS232 interface					
Output Voltage Swing	±4.32	±4.67		V	$R_{LOAD} \geq 3\text{ k}\Omega$
Input Voltage Swing	-25		+25	V	
Input Threshold LOW	0,45			V	
Input Threshold HIGH			3,1	V	
Input Resistance	4	6	8	k Ω	
ESD voltage (Human Body Model)		± 15		kV	
ESD voltage (Air Discharge)		± 15		kV	
ESD voltage (Direct Contact)		± 8		kV	
Site conditions					
Air humidity (non-condensing)			85	%	
Operating temperature of the GSM/GPRS modem	-20	25	55	°C	

PARAMETER	MIN.	TYP.	MAX.	UNIT	CONDITIONS
Power pack MC1213114-45-EU/-UK/-US					
Input voltage	100		240	V _{AC}	
Input current			400	mA _{AC}	
Output voltage	10,5	12	13,5	V _{DC} (V ₋₋₋)	
Operating temperature	0	25	40	°C	
Storage temperature	-40		70	°C	
Air humidity (non-condensing)	5		95	%	
Weight		130		g	
¹⁾ The maximum power input depends on the used GSM net and also on the (antenna -) signal quality. Usually the power input is higher with 850 MHz and/or. 900 MHz than with 1800 MHz and/or. 1900 MHz nets. With small signal quality the max. power input rises. Currency-data apply to power control level PCL? 5, without LED current, with switched off buzzer and without currents over the RS-232-interface.					
²⁾ The maximum current $I_{PWR, MAX, PEAK}$ appears as a burst on speech- or GPRS-connections with a length of approx. 580µs. The average power input lies clearly under this.					

Table 19: Technical Data

9.1 Use of alternative voltage supplies

When using alternative voltage supplies the instructions in chapter "Voltage supply" (Page 8) are to be followed.

In order to meet the CE conformity, a Low-ESR condenser with at least 1000µF is to be inserted directly to the GSM/GPRS modem at PLUS (pin 1) and MINUS (pin 6)!

Recommended electrolytic capacitor during alternative voltage supply:

Aluminium-Elektrolytkondensator (FROLYT Baureihe ERF)			
Parameter:		Wert	Einheit
Nominal capacity:	C _R	100	µF
Rated voltage:	U _R	63	V
Dimensions:	D x L	16,5 x 30	mm x mm
Dissipation factor (100 cycles per second at +20°C):	tan δ	0,07	1
Apparent impedance (100 kHz with +20°C):	Z	0,06	Ω
Manufacturer:	FROLYT GmbH Dammstraße 46 D-09599 Freiberg Phone: 049 (0)3731 571 300 Fax: 049 (0)3731 571 317 www.frolyt.de		

Table 20: Aluminum electrolytic capacitor during alternative voltage supply

9.2 Protection from temperature rise

GSM connections always require that the equipment sends data to the GSM network. With bad transmission conditions (e.g. with larger distance to the next antenna of the network operator) this can require so much energy that it leads to a rise in temperature of the equipment.

For protection from overheating the GSM/GPRS modem has protective mechanisms. If it should come to a heating, the GSM/GPRS modem switches off.

The GSM/GPRS modem can slightly warm up when in use. If it should come to a clear heating up (over approx. 70°C), then you must definitely switch the equipment off!

Examine the position of the antenna. A slight reorientation of the antenna can often improve the receiving and transmission quality substantially.

Please consider the following informations:

- **The GSM/GPRS modem may never be covered. The slots around the connectors may not be covered or taped. When installing the GSM/GPRS modem make sure of good exhaustion of the assembling place!**
- **The surrounding temperature should be approx. ambient temperature.**
- **Only use certified, high-quality antennas and consider the assembly and operating instructions. Bad antennas or bad receipt conditions increase the GSM/GPRS modem capacity unnecessarily.**
- **GSM- and GPRS connections in 1800 MHz and 1900 MHz nets need far less power than in 900 MHz nets.**
- **Operate the equipment only with the prescribed power packs!
Supply voltage with speech and GPRS connections must amount to at least 12 to 15 V!**

9.2.1 Information on use in longer GPRS - Class 10 connections

GPRS connections are very power intensive. If the GSM/GPRS modem in that case should warm up too much, it is changed automatically from GPRS Class 10 to GPRS Class 8 for the protection of the equipment.

10 Dimensions

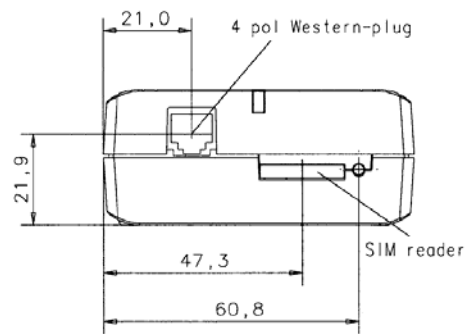

Illustration 9: mechanical dimensions (rear view)

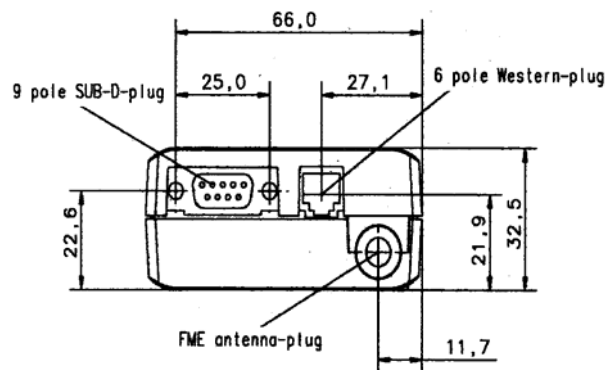

Illustration 10: mechanical dimensions (front view)

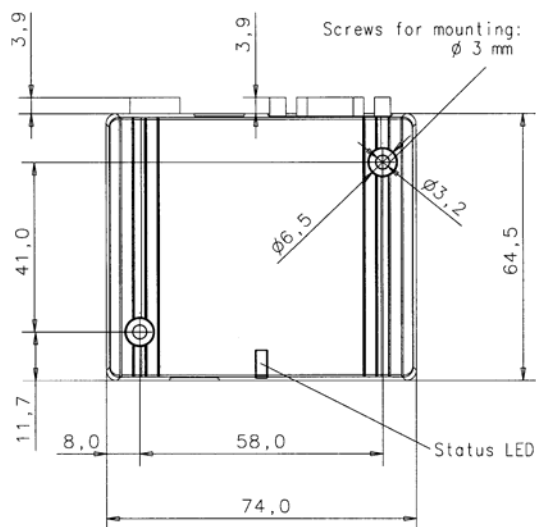

Illustration 11: mechanical dimensions (view on top)

11 Permissions, conformity

If the GSM/GPRS modem is integrated in systems or devices, then the manufacturer of the final product is responsible for meeting the standards, recommendations, regulations and standards.

Due to the integration of the Cellulare Engines in the GSM/GPRS modem one differences between the permissions of the Cellulare Engines and the complete GSM/GPRS modem.

11.1 Cellular Engines, Type Approvals

The Cellular Engines which are integrated in the GSM/GPRS modem fulfill the following directives and standards for integration GSM /GPRS applications.

Cellular Engine	Description / Comment	SIEMENS				Triorail TRM:1 ⁵⁾
		MC45 ¹⁾	MC46 ²⁾	MC388 ³⁾	TC45 ⁴⁾	
European directives						
99/05/EC	Directive of the European Parliament and of the council of 9 March 1999 on radio equipment and telecommunications terminal equipment and the mutual recognition of their conformity., in short referred to as R&TTE Directive 1999/5/EC	✓	✓	✓	✓	✓
89/336/EC	Directive on electromagnetic compatibility	✓	✓	✓	✓	✓
73/23/EC	Directive on electrical equipment designed for use within certain voltage limits (Low Voltage Directive)	✓	✓	✓	✓	✓
Standards of North American Type Approval						
CFR Title 47	Code of Federal Regulations, Part 2 and Part 24 (Telecommunications, PCS). US Equipment Authorization FCC	✓	✓	-	-	-
UL 60 950	Product Safety Certification. (Safety requirements)	✓	✓	-	-	-
NAPRD.3	Overview of PCS Type certification review board Mobile Equipment Type Certification and IMEI control. PCS Type Certification Review board (PTCRB)	✓	✓	-	-	-
Standards of European Type Approval						
3GPP TS 51.010-1	Digital cellular telecommunications system (Phase 2); Mobile Station (MS) conformance specification.	✓	✓	✓	✓	✓
ETSI EN 301 511	V7.0.1 (2000-12) Candidate Harmonized European Standard (Telecommunications series) Global System for Mobile communications (GSM); Harmonized standard for mobile stations in the GSM 900 and DCS 1800 bands covering essential requirements under article 3.2 of the R&TTE directive (1999/5/EC) (GSM 13.11 version 7.0.1 Release 1998).	✓	✓	✓	✓	✓
GCF-CC	Global Certification Forum - Certification Criteria.	✓	✓	✓	✓	✓
ETSI EN 301 489-1	V1.1.1 (2000-09) Candidate Harmonized European Standard (Telecommunications series) Electro Magnetic Compatibility and Radio spectrum Matters (ERM); Electro Magnetic Compatibility (EMC) standard for radio equipment and services; Part 1: Common Technical Requirements.	✓	✓	✓	✓	✓
ETSI EN 301 489-7	V1.1.1 (2000-09) Candidate Harmonized European Standard (Telecommunications series) Electro Magnetic Compatibility and Radio spectrum Matters (ERM); Electro Magnetic Compatibility (EMC) standard for radio equipment and services; Part 7: Specific conditions for mobile and portable radio and ancillary equipment of digital cellular radio telecommunications systems (GSM and DCS).	✓	✓	✓	✓	✓
EN 60 950	Safety of information technology equipment (2000)	✓	✓	✓	✓	✓
Requirements of quality						

Cellular Engine	Description / Comment	SIEMENS				Triorail
		MC45 ¹⁾	MC46 ²⁾	MC388 ³⁾	TC45 ⁴⁾	TRM:1 ⁵⁾
IEC 60068	Environmental testing	✓	✓	✓	✓	✓
DIN EN 60529	IP codes	✓	✓	✓	✓	✓
Compliance with FCC Rules and Regulations						
FCC identifier:		<i>QIPMC45</i>		-	-	-
FCC identifier granted to:		<i>Siemens AG</i>		-	-	-
	The device is to be used only for mobile and fixed applications. The antenna(s) used for this transmitter must be installed to provide a separation distance of at least 20 cm from all persons and must not be co-located or operating in conjunction with any other antenna or transmitter. Users and installers must be provided with antenna installation instructions and transmitter operating conditions for satisfying RF exposure compliance. The device is approved as a module to be installed in other devices. Each OEM must obtain their own Certification for each device containing this module.	✓		-	-	-
GSM-R						
R&TTE - EN 301 419-7 (GSM-R) V.5.0.2	Official R&TTE version based on the latest EJ publication and GSM 13.67	-	-	-	-	✓
✓ available - not available TBD to be defined						
¹⁾ Data Sheet: MC45_HD_V02.04a; 11.04.2003 ²⁾ Data Sheet: MC46_HD_V02.8x; 02.07.2003. Pre-release state! Type approval and testing procedures have not yet been completed! ³⁾ Data Sheet: MC388_HD_V02.04; 17.02.2003 ⁴⁾ Data Sheet: TC45_HD_V01.00a; 30.06.2003 ⁵⁾ Data Sheet: ...						
The reference setup that will be submitted to type approve of the cellular engines consists of the following components: <ul style="list-style-type: none"> • cellular engine • Development Support Box (DSB45) • Flex cable (160 mm) from Hirose DF12C receptacle on cellular engine to Hirose DF12 connector on DSB45. Please note that this cable is not included in the scope of delivery of DSB45. • SIM card reader integrated on DSB45 • Handset type Votronic HH-SI-30.3/V1.1/0 • PC as MMI 						

Table 218: Permissions of the Cellular Engines

11.2 GSM/GPRS modem

The GSM/GPRS modem - with integrated Cellular Engine SIEMENS MC45 – has been tested according to the following standards and/or fulfills the respective requirements:

Test Regulation	Category
EN 61000-4-2 / 3.1995 + A1:4.1998 + A2:2.2001	EMC
EN 61000-4-3 / 9.1996 + A1:8.1998 + A2:2.2001	EMC
EN 61000-4-4 / 3.1995 + A1:2.2001	EMC
EN 61000-4-5 / 3.1995 + A1:2.2001	EMC
EN 61000-4-6 / 7.1996 + A1:2.2001	EMC
EN 61000-4-11 / 8.1994	EMC
EN55022 / 1998+ A1: 2000 – Class B	EMC
EN 61000-3-2 / 1995 + A1:1998 + A2:1998 + A14:2000	EMC
EN 61000-3-3 / 1995	EMC
EN 301 489-1 V1.4.1 / 08.2002	EMC Standard for radio equipment services; Part 1: Common technical equipment
EN 301 489-7 V1.2.1 / 08.2002	EMC Standard for radio equipment services; Part 7: Specific conditions for mobile and portable radio and ancillary equipment of digital cellular radio telecommunications systems (GSM and DCS)
EN55022 / 5.1995 – Class B	Emission
47 CFR Part 15 Subpart B (FCC) – Class B	Emission
EN60950:2000	Safety of information technology equipment

Table 22: Permissions, conformity of the GSM /GPRS modem

Further permissions in preparation and on request.

DECLARATION OF CONFORMITY

Directive 99/5/EC (R&TTED)

Manufacturer or
Authorized representative: **MC Technologies GmbH**

Address: **Ahrensburger Strasse 8
30659 Hannover
Germany**

We declare on our sole responsibility, that the following product:

Kind of equipment: GSM – GPRS - Terminal

Type-designation: MC45T, MC45TL

is in compliance with the essential requirements of §3 of the R&TTED.

- Health and safety requirements pursuant to §3(1)a:
Applied Standard(s) or other means of providing conformity:
EN 60950-1: 2001

- Protection requirements concerning EMC §3(1)b:
Applied Standard(s) or other means of providing conformity:
EN 301 489-7 V1.2.1: 8/2002

- Measures for the efficient use of the radio frequency spectrum §3(2)
Applied Standard(s) or other means of providing conformity:
(Radio test report for the GSM module MC45)

Hannover, 1st March 2004

place and date of issue



Andreas Schober

Manufacturer/Authorized representative
name and signature

Accredited testlaboratory: MIKES BABT SERVICE GmbH, Ohmstrasse 2-4
94342 Strasskirchen, Germany

Illustration 121: Conformity explanation

11.2.1 FCC Conformity

11.2.1.1 MC45T/MC45TL



TEST RESULT SUMMARY

FCC PART 15 SUBPART B Class B Limit

MANUFACTURER'S NAME	MC Technologies GmbH
NAME OF EQUIPMENT	GSM – GPRS - Terminal
MODEL NUMBER	MC45T / MC45TL
MANUFACTURER'S ADDRESS	Kabelkamp 3 30179 Hannover Germany
RESPONSIBLE PARTY	MC Technologies GmbH Kabelkamp 3 30179 Hannover Germany
TEST REPORT NUMBER	Mikes BAPT Product Service T 23576-01-01KJ
TEST DATE	01 July – 26 November 2003

According to testing performed at Mikes BAPT Product Service, the above-mentioned unit is in compliance with the electromagnetic compatibility requirements defined in FCC Part 15.

It is the manufacturer's responsibility to assure that additional production units of this model are manufactured with identical electrical and mechanical characteristics. Any modifications necessary for compliance made during testing on the above mentioned date(s) must be implemented in all production units for compliance to be maintained. The manufacturer (the responsible party) may issue a Declaration of Conformity following the requirements stated in CFR 47, Part 2, Sections 2.1071-2.1077. The labeling requirements are listed in CFR 47, Part 15, Section 15.19.

TÜV America Inc, as a NVLAP accredited independent testing laboratory, declares that the equipment tested as specified above conforms to the requirements of FCC Part 15.

Date: 21 December 2003

TUV AM project:
NC305700

Location: Taylors Falls MN
USA

J. T. Schneider
NVLAP Signatory

Not Transferable

11.2.1.2 MC46T/MC46TL



TEST RESULT SUMMARY

FCC PART 15 SUBPART B Class B Limit

MANUFACTURER'S NAME	MC Technologies GmbH
NAME OF EQUIPMENT	GSM – GPRS Terminal
MODEL NUMBER	MC46T / MC46TL
MANUFACTURER'S ADDRESS	Ahrensburger Str. 8 30659 Hannover Germany
RESPONSIBLE PARTY	MC Technologies GmbH Ahrensburger Str. 8 30659 Hannover Germany
TEST REPORT NUMBER	mikes-testing partners gmbh T23576-01-01KJ
TEST DATE	01 July - 26 November 2003

According to testing performed at mikes-testing partners gmbh, in addition to verification from Siemens that the above-mentioned unit is technically identical to the MC45T/MC45TL product, the above-mentioned product is in compliance with the electromagnetic compatibility requirements defined in FCC Part 15.

It is the manufacturer's responsibility to assure that additional production units of this model are manufactured with identical electrical and mechanical characteristics. Any modifications necessary for compliance made during testing on the above mentioned date(s) must be implemented in all production units for compliance to be maintained. The manufacturer (the responsible party) may issue a Declaration of Conformity following the requirements stated in CFR 47, Part 2 Section 2.1071-2.1077. The labeling requirements are listed in CFR 47, Part 15 Section 15.19.

TÜV America Inc, as a NVLAP accredited independent testing laboratory, declares that the equipment tested as specified above conforms to the requirements of FCC Part 15.

Date: 03 November 2005

TUV AM project:
WC505404-1

Location: Taylors Falls MN
USA

J. T. Schneider
NVLAP Signatory

Not Transferable

11.3 Adherence to international rules and regulations

Manufacturers of mobile, stationary or portable devices, which integrate the GSM/GPRS modem, must permit their complete equipment in accordance to the national and international regulations. For the European market the R&TTE Direktiven and GCF Certification Criteria, for the North American market the Federal Communications Commission (FCC) and PTCRB regulations must be fulfilled.

11.3.1 SAR- guidelines for 'handheld mobiles'

Mobile phones, PDAs and other 'handheld' transmitters and receivers must meet the guidelines concerning the "Specific Absorption Rate" (SAR).

The necessity for an additional permission and the limit values depend on the respective national and international regulations and on the final product, into which the is integrated.

- Products for US market:
 - ES 59005/ANSI C95.1
Considerations for evaluation of human exposure to Electromagnetic Fields (EMFs) from Mobile Telecommunication Equipment (MTE) in the frequency range 30MHz-6GHz.
- Products for EU market:
 - EN 50360
Product standard to demonstrate the compliance of mobile phones with the basic restrictions related to human exposure to electromagnetic fields (300 MHz - 3 GHz).

12 Accessoires





	900/1800/1900 MHz / UMTS sticking antenna, 30DB, 3m RG174 FME (female), Ø 53mm (MC0114013)
	GSM 900/1800/1900 MHz sticking antenna, 0 DB, 3m cable RG174, FME (female) (MC0114069)
	Power pack incl. connecting cable / Western plug (MC1213114-45-EU, 100V AC ... 240V AC; AC input connector: EURO) (MC1213114-45-UK, 100V AC ... 240V AC; AC input connector:UK) (MC1213114-45-US, 100V AC ... 240V AC; AC input connector:USA/Japan)
	Handset (MC1213225)
	Data cable 2,0m, 9 pin plug - 9 pin jack (MC1213226-1m)

Table 23: Accessoires

13 Cleaning of the equipment

Clean the housing with a soft cloth, which you have moistened slightly with a mild cleaning solution. Do not use any scrubbing means, scrubbing sponges or solvents such as alcohol, benzene or gasoline.

14 Maintenance, repair

The GSM/GPRS modem is maintenance-free. For security reasons you are strongly recommended to check the cables and lines regularly for damages and replace damaged or broken lines immediately!

In the GSM/GPRS modem there are no parts, which are exchangeable by the user - also no safety devices such as fuses!

Repairs may be accomplished only by specialized companies authorized by the manufacturer!

In the case of a necessary repair, maintenance or an examination return the equipment to the dealer, where you purchased the GSM/GPRS modem !

15 Short terms

CE.....	Conformité Européene (European Conformity)
CHAP	Challenge Handshake Authentication Protocol
CS.....	Coding Scheme
CSD	Circuit Switched Data
CTS.....	Clear to Send
Data Communication Equipment	(typically modems, e.g. Siemens GSM engine)
DCS 1800	Digital Cellular System, also referred to as PCN
DSR	Data Set Ready
DTE	Data Terminal Equipment (typically computer, terminal, printer or, for example, GSM application)
DTR	Data Terminal Ready
EFR.....	Enhanced Full Rate
EGSM	Enhanced GSM
EMC	Electromagnetic Compatibility
ESD	Electrostatic Discharge
FR.....	Full Rate
GPRS.....	General Packet Radio Service
GSM.....	Global Standard for Mobile Communications
HR	Half Rate
I/O.....	Input/Output
IMEI.....	International Mobile Equipment Identity
kbps.....	kbits per second
LED.....	Light Emitting Diode
MMI	Man Machine Interface
MO.....	Mobile Originated
ms	Milli Seconds (1000 ms = 1 s)
MS.....	Mobile Station (GSM engine), also referred to as TE
MT.....	Mobile Terminated
PBCCH	Packet Switched Broadcast Control Channel
PCL.....	Power Control Level
PCM	Pulse Code Modulation
PCN	Personal Communications Network, also referred to as DCS 1800
PCS.....	Personal Communication System, also referred to as GSM 1900
PDU	Protocol Data Unit
PPP.....	Point-to-point protocol
R&TTE	Radio and Telecommunication Terminal Equipment
RF.....	Radio Frequency
Rx.....	Receive Direction
SAR.....	Specific Absorption Rate
SIM.....	Subscriber Identification Module
SMS	Short Message Service
TA	Terminal adapter (e.g. GSM engine)

TBD To be defined
TE..... Terminal Equipment, also referred to as DTE
Tx..... Transmit Direction
USSD Unstructured Supplementary Service Data

